

LOC		DIST		ZONE		LTR		REVISIONS			
CM	52	P	F					DESCRIPTION	DATE	APPD	
								K	REV & REDWN PER EC 0730-0072-94	6-9-93	K5

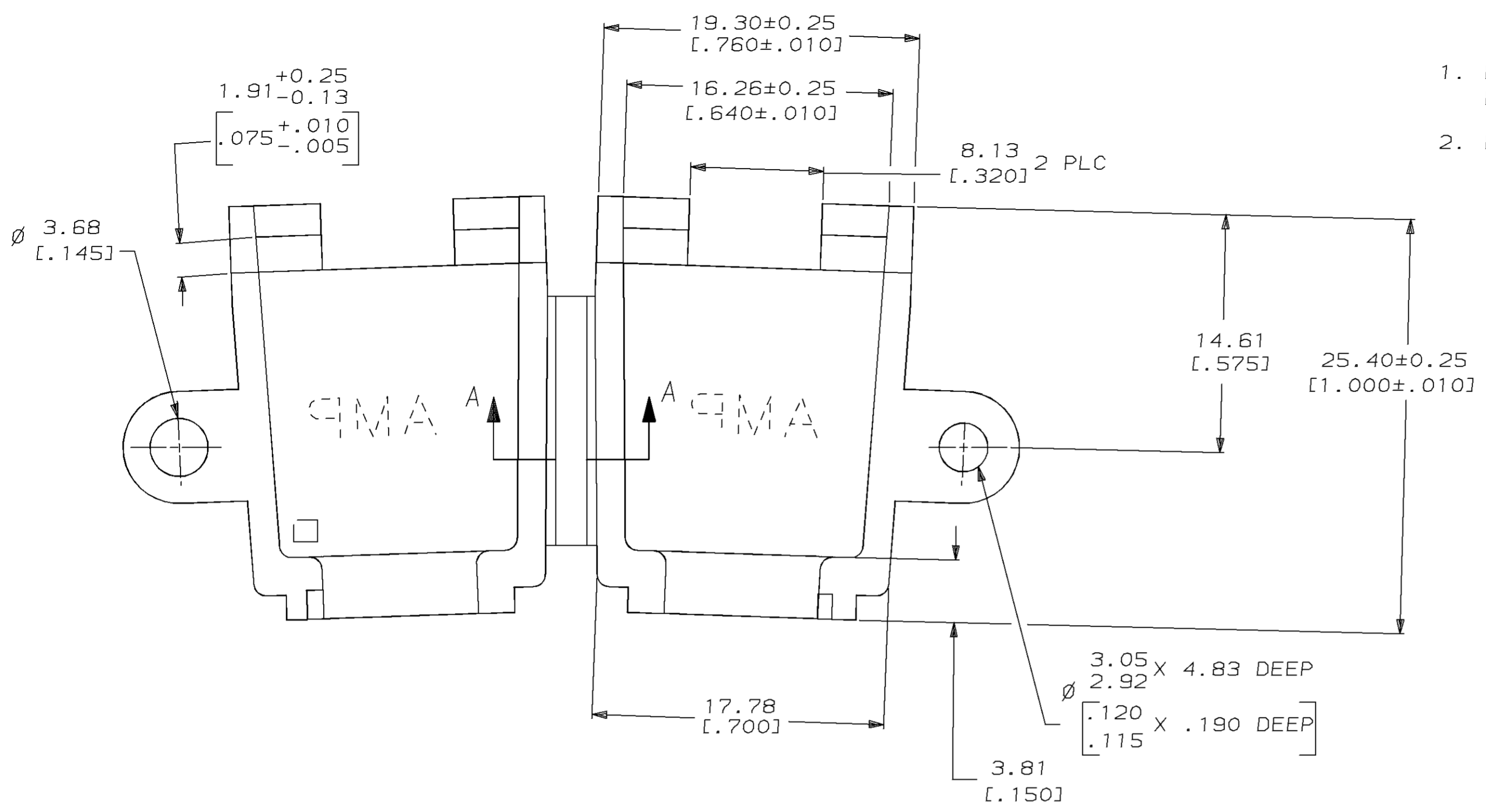

- REQUIRES A #6 PAN HEAD TYPE "B" SELF TAPPING PAN HEAD SCREW, 9.53 [.375] LONG.
- DIMENSIONS IN BRACKETS ARE IN INCHES.

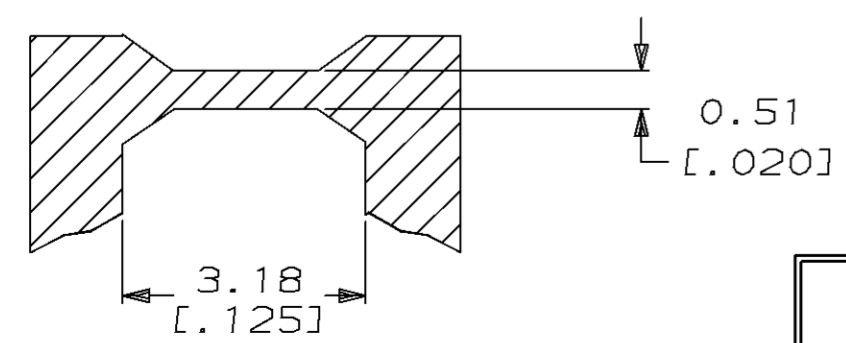
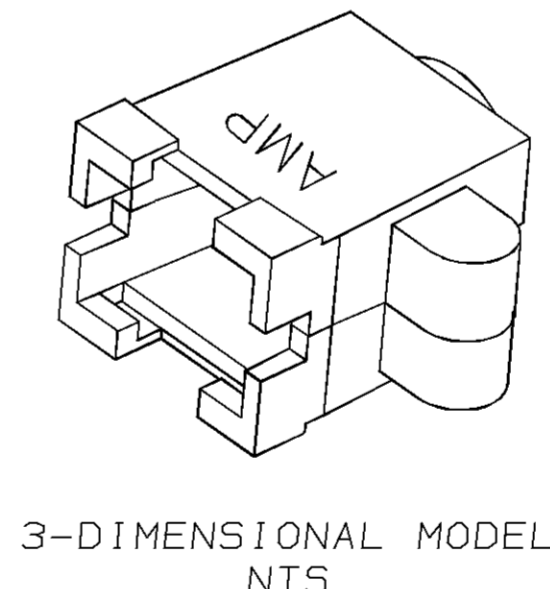
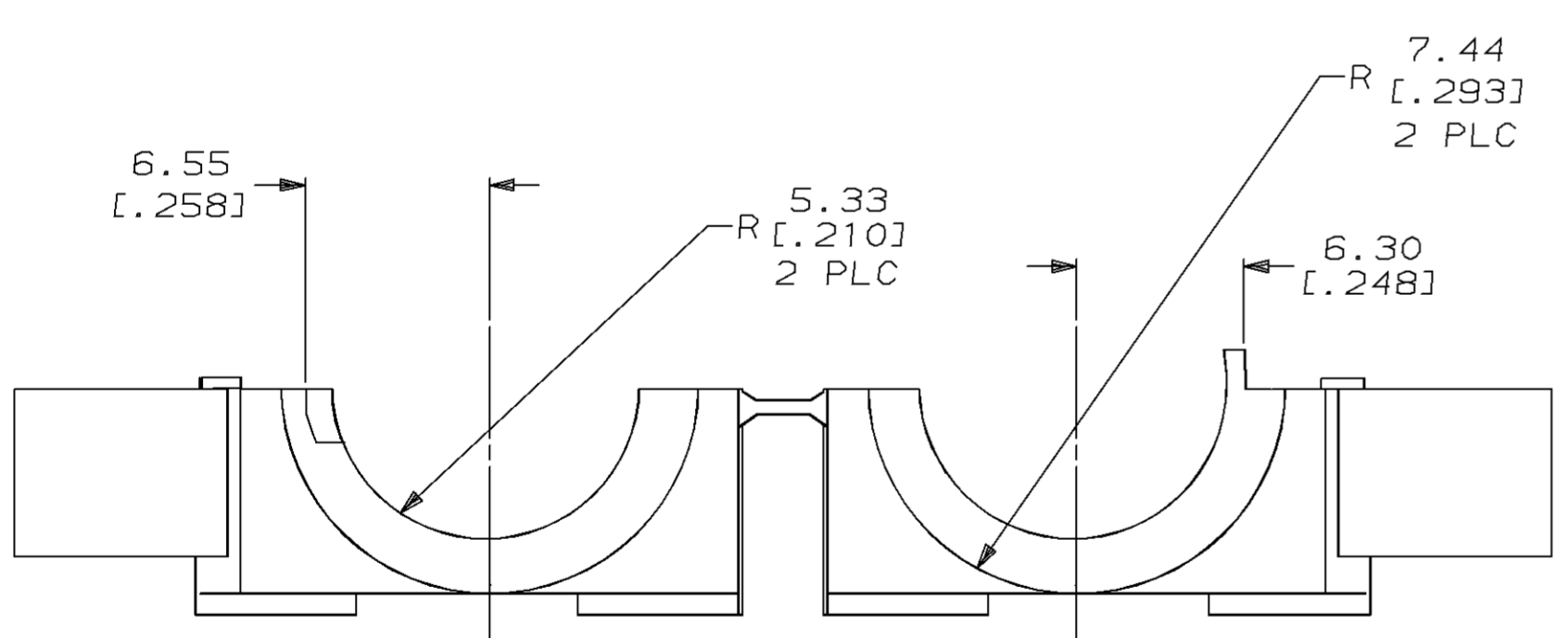
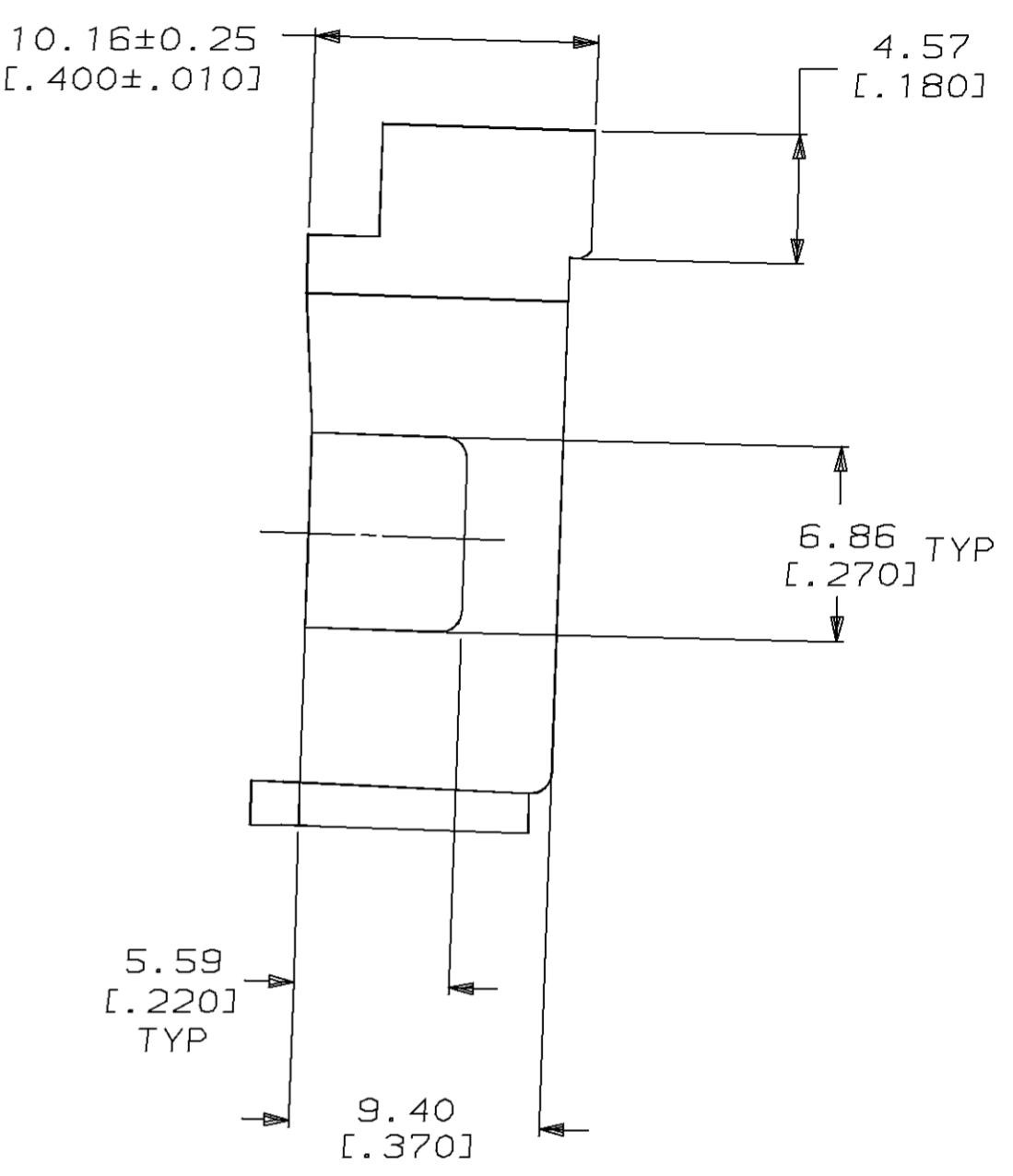

**METRIC**

THIS DRAWING IS A CONTROLLED DOCUMENT FOR AMP INCORPORATED. IT IS SUBJECT TO CHANGE AND THE CONTROLLING ENGINEERING ORGANIZATION SHOULD BE CONTACTED FOR THE LATEST REVISION.

BLACK	1-350522-9
BRICK RED	350522-1
COLOR	PART NO

DO NOT SCALE PRINT. UNLESS SPECIFIED DIMENSIONS IN mm [INCHES] TOLERANCES ON : 2 PLC DEC ± 0.13 [.005] 3 PLC DEC ± - ANGLES ± -	DR 6-9-93 K. SALMON CHK 6-9-93 R. SWING	<b>AMP</b> AMP Incorporated Harrisburg, PA 17105-3608	
MATERIAL NYLON	APPD - W. LONG	NAME STRAIN RELIEF, HINGED, 9 POSITION	
FINISH COLOR, SEE TABLE	APPD - W. LONG PRODUCT SPEC -	SIZE C	CAGE CODE 00779
	APPLICATION SPEC -	DRAWING NO G=350522	
	WEIGHT -	SCALE 4:1	SHEET 1 OF 1

CUSTOMER DRAWING